



GORILLA® MATRIX (COLUMN/POST) INSTALLATION GUIDELINES

FEATURES:

- Matrix™ Baseplate system can accommodate a variety of internal supports, including 3.5" and 2.375" diameter metal tubes, and 4"x 4" (nominal) wood posts.
- Gorilla Columns are available in a variety of dimensions, including 8.4" and 6-5/8" diameter round, and 8", 6-1/2", and 5" square.
- Transition assemblies allow for a variety of additional looks including:
 - 8" Square to 6-1/2" Square
 - 8" Square to 6-5/8" Round
 - 8" Square to 5" Square
 - 6-1/2" Square to 5" Square
- Standard 9' and 10' lengths

REQUIRED TOOLS AND MATERIALS:

- Safety glasses
- Power drill/driver with 5/16" hex drive and #2 phillips head drive
- #3 Phillips-head screwdriver
- Measuring tape
- Non-marking rubber mallet
- Waymark PVC cement
- Surface mounting hardware is NOT included. Required fasteners will depend on the porch/roof structure and material for the project.
- Reciprocating saw with fine-tooth (hack-saw) blade if column or transition sections are to be cut to length.

The Gorilla Column system is intended for use as a porch post, with at least one side of the porch deck and roof attached to an adjoining building or structure to provide lateral support. Gorilla Columns are NOT intended to be used for free-standing structures, i.e. pergolas, gazebos, etc. It is the installer's responsibility to consult the local building codes prior to installation of Gorilla Columns.

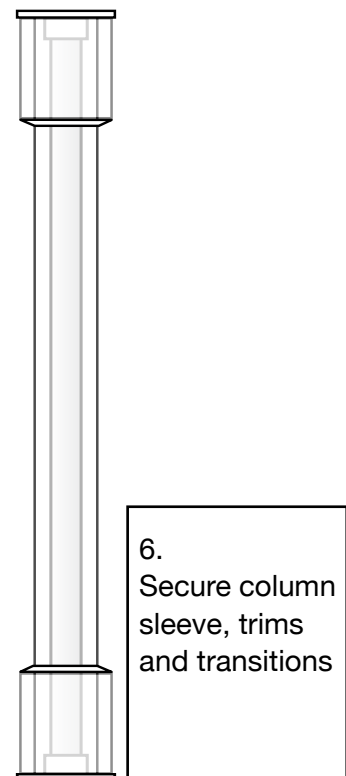
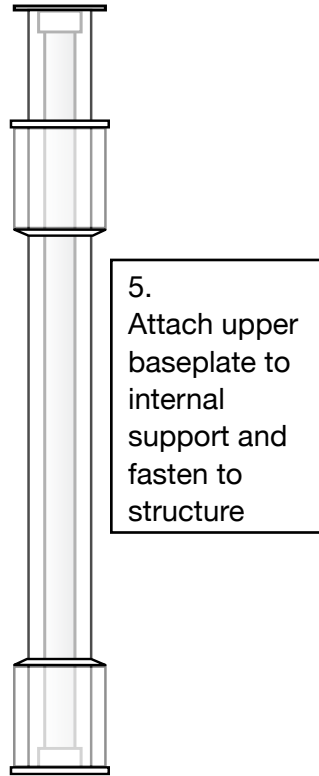
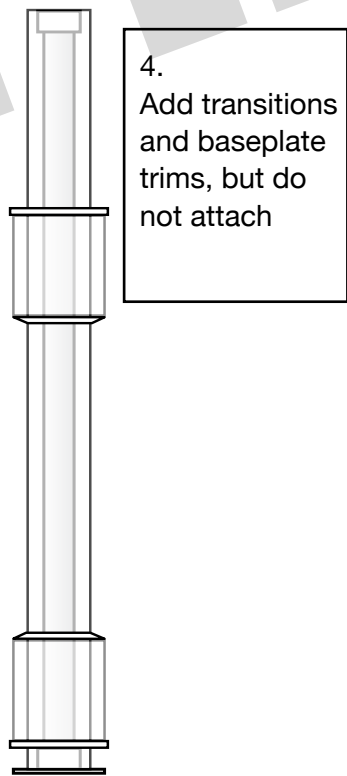
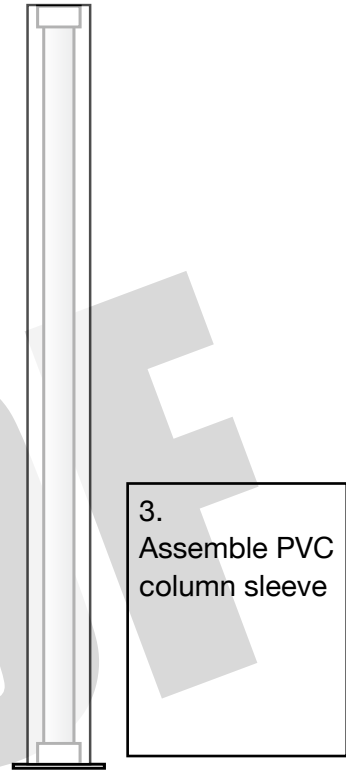
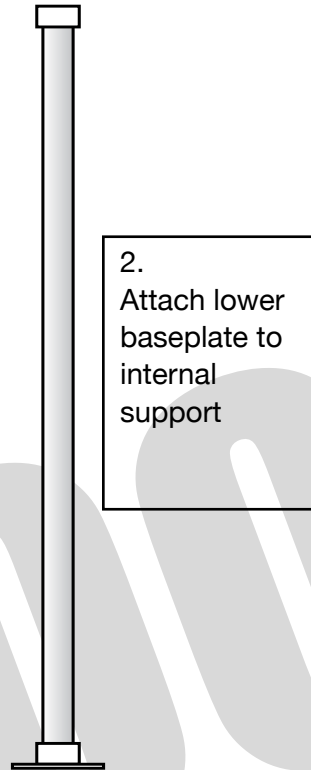
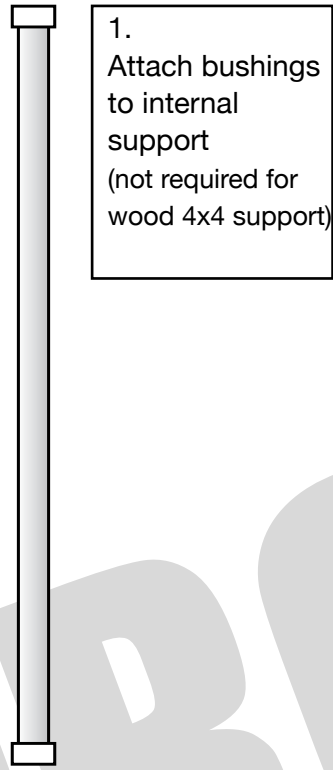

1. COMPONENT DESCRIPTION

Each Gorilla Column/Post requires the following:

A. Matrix™ Universal Baseplate Kit. Each kit includes:

- (2) Matrix™ baseplates
- (2) Structural support bushings (not required for wood 4x4 support)
- (2) Baseplate cover
- (1) Hardware pack:
 - (8) 1-1/2" #12 hex-head self-drilling screws
 - (8) 3/4" #14 Phillips-head sheet metal screws
 - (8) 1" #10 self-drilling screws

Wood 4x4 support installation requires

- (8) 3" #14 flathead countersunk wood screws (not included)

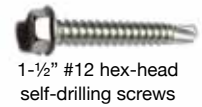

1-1/2" #12 hex-head self-drilling screws



3/4" #14 phillips-head sheet metal screws



1" #10 self-drilling screws

Matrix Baseplate

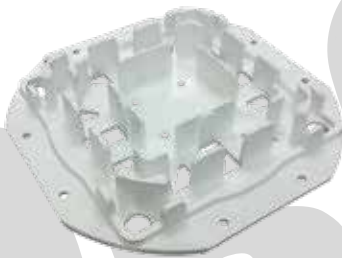

Bushing Trim



Universal Base

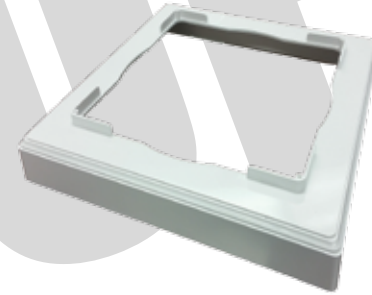

B. Internal support member

2-3/8" or 3-1/2" diameter, 13 ga. (0.095") galvanized steel tube

C. PVC column sleeve

Round sleeves are available in 8.4" or 6-5/8" diameters

Square sleeves are available in 8", 6-1/2", or 5" dimensions

D. Column trim rings (2)

Column trim rings are selected according to the chosen column/post sleeve, or transition sleeve, if a transition assembly is used.

E. Transition assembly components

Transitions can be made by using partial lengths of PVC column sleeves and transition trim rings.

The transition sleeve is cut to length and installed at either or both ends of the column/post assembly.

For example, the column/post can transition from an 8" x 8" square at the base to a 6-5/8" diameter round. Transition trim rings are available in the following combinations:

- 8" square to 6-1/2" square
- 8" square to 6-5/8" round
- 8" square to 5" square
- 6-1/2" square to 5" square

2. PREPARATION

A. General

- Review local building codes.
- Handle PVC components with care. Do not place on rough surfaces during assembly, or PVC surface may be scratched.
- Measure the opening where the Gorilla Column is to be installed. Standard Gorilla Column lengths are 9' and 10' (including baseplates); if using an alternate length, deduct 3/8" from the PVC column/post sleeve length and 5/8" from the internal support length to account for the thickness of the Baseplates and support bushings.
- NOTE: Gorilla Columns are assembled and then placed in the final location. Tilting up the column will require approximately 1" clearance beyond the nominal 9' column height.
- The baseplate cover and column trim ring should be assembled using PVC cement prior to assembly and set aside until ready for installation.
- If the Column is to include transitions, the PVC transition sleeve and trim should be assembled using PVC cement and set aside until ready for installation

B. Porch Structure/Blocking

Determine the location of the columns and ensure that adequate support is available for securely attaching the column baseplates to the porch roof and deck structure. See Figure 2.1 for suggested blocking in a wood structure. If columns are to be set on a concrete surface, determine the concrete anchor locations. Do NOT attach baseplates to structure at this time.

Figure 2.1

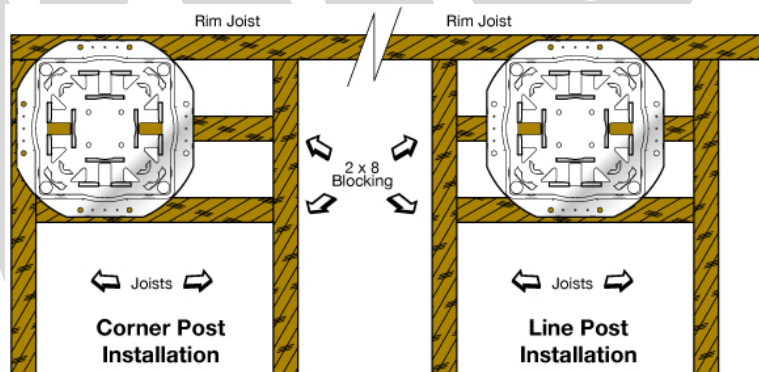

C. Support Bushing Assembly (not required for wood 4x4 support)

Fit the support bushings to the ends of the internal support. Fit should be snug. Laying the support assembly on a flat surface will assure that the two bushings are lined up square on both ends. See Figures 2.2a and 2.2b.

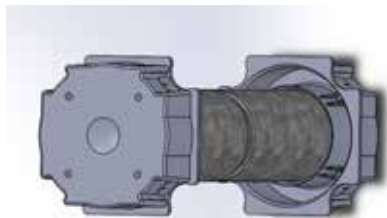

Figure 2.2a - Correct

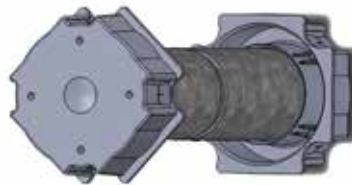

Figure 2.2b - Incorrect

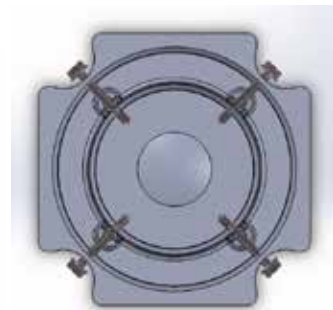

Figure 2.3

Attach bushing to internal support using four (4) 1-1/2" #12 hex-head self-drilling screws placed in the corners of the bushing. See Figure 2.3.
Repeat for other end of internal support

3. COLUMN/POST ASSEMBLY

A. Connect Baseplate to Internal Support

(For steel tube and bushing support): Place a Matrix™ baseplate onto one end of the bushing/support assembly. Use four (4) 3/4" #14 Phillips-head screws through the bottom of the baseplate into the bushing. It is recommended that the 3/4" screws be inserted manually, rather than with a drill or power driver, in order to avoid stripping material from the inside of the bushing. See Figure 3.1.

(For wood 4x4 support): Place a Matrix™ baseplate onto one end of the 4" x 4" wood post. Using the baseplate as a guide, mark the location of the screw holes on the end of the post. Drill appropriate pilot holes to receive 3" #14 wood screws. Fasten baseplate to 4 x 4 post using (4) 3" #14 flathead countersunk wood screws.

NOTE: Do not attach the second baseplate to the opposite end of the Internal Support until the column assembly is completed. Further assembly requires that one end of the column be open to allow installation of the PVC column sleeve, transition assemblies, and trim pieces.

B. Install Column/Post Sleeve

Slide the PVC column sleeve over the Internal Support and fit into the corresponding tabs on the attached Matrix™ baseplate. Secure the column sleeve to the baseplate using four (4) 1" self-drilling #10 screws through the baseplate tabs (one screw for each side of the baseplate). See Figure 3.2.

C. Place Transitions and Trims on Column Assembly

All transition and trim pieces should be placed on the column sleeve in their proper orientation before installation of the second baseplate. Generally, transitions and trims are installed in the following order:

- 1) Baseplate cover and trim ring for lower baseplate
- 2) Transition assembly for lower baseplate, if applicable
- 3) Transition assembly for upper baseplate, if applicable
- 4) Baseplate cover and trim ring for upper baseplate

D. Attach Top Baseplate and Secure PVC Column Sleeve

Align upper baseplate with internal support bushing and PVC column sleeve. Attach using four (4) 3/4" #14 Phillips-head screws through baseplate. Secure the PVC Column/Post sleeve to the corresponding tabs located on the upper baseplate using four (4) 1" self-drilling #10 screws

Figure 3.1

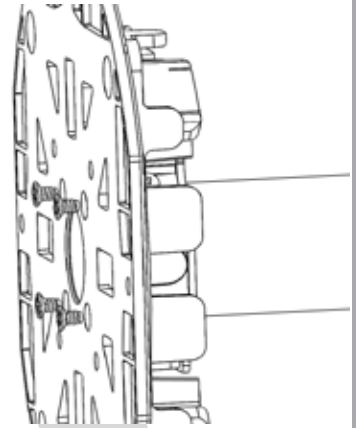
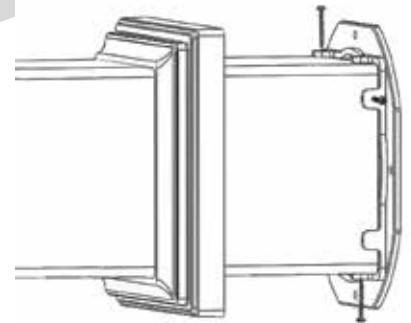

Figure 3.2



4. COLUMN/POST PLACEMENT & FINISHING

A. Secure Gorilla Column Assembly in Place.

Ensure blocking or acceptable support is in place to provide adequate attachment of the Column Assembly. Fasten baseplates to porch deck and roof structure using appropriate fasteners (not included in hardware pack).

- The Matrix baseplate rim has two holes in each side for mounting along joists or other blocking running parallel to the base plate edge. The Matrix baseplate rim also includes three dimples to guide installation of fasteners when blocking runs perpendicular to base plate edge. See Figure 2.1

B. Attach Transition Assemblies and Baseplate Covers

If Transitions are used, secure the Transition assembly to the corresponding tabs located on the upper and lower baseplates using four (4) 1" #10 self-drilling screws (not included in hardware pack). Attach the baseplate cover/trim assemblies by snap-fit to the edges of the baseplate. PVC cement may also be used.

C. Attach Guardrail Brackets

Waymark Summit guardrail brackets may be attached to the Gorilla column, either directly to a square post, or using an adaptor to a round column. The brackets must be attached using 1-1/2" #8 Hi-Lo thread self-tapping screws (not included).

NOTES:

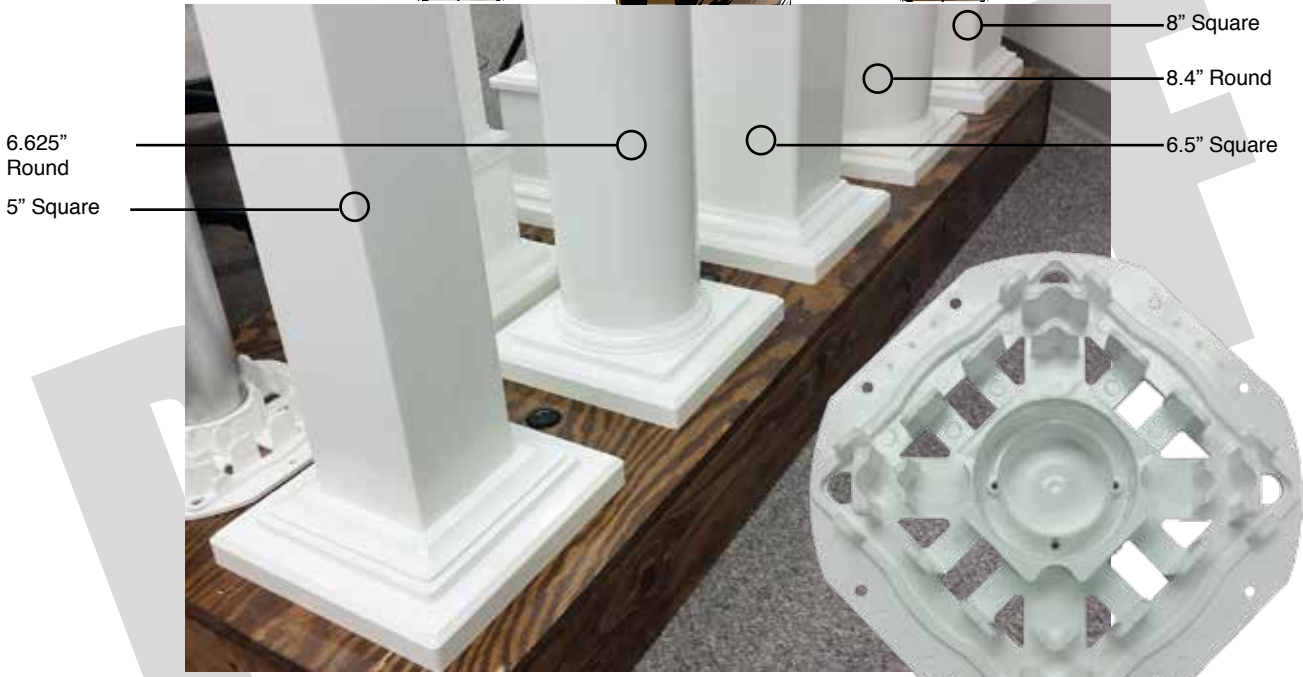

Gorilla Matrix is the single mounting plate needed to install every size column or post from 5" x 5" up to 8.4" round.

PROOF